

Verb Movement, Objects, and Serialization

Mark C. Baker and O.T. Stewart

Rutgers University

In this paper, we analyze a certain process of Verb to Infl raising in the Edo language of Nigeria. Verb raising has not been recognized in previous work on Edoid languages, such as Agheyisi 1990. From a theoretical perspective, its primary interest comes from the fact that it takes place only in one tense. As a result, it is easy to form minimal pairs with and without verb raising in the same language, thereby shedding light on certain theoretical issues surrounding verb movement. In particular, verb raising interacts with transitivity in Edo in a way that has implications for the mechanisms of accusative Case checking. Verb raising is also incompatible with Serial Verb Constructions, which are otherwise common in Edo. This can be explained by a certain refinement in Chomsky's definition of Attract. As a fall-out of the proposal, we can explain why some Serial Verb Constructions in Edo correspond to verb-verb compounds in languages like Igbo and Chinese, while others do not. We can also explain why the order of morphemes in these verb-verb compounds is not what one would expect, when compared to other verb movement constructions.

1. Basic Properties of Verb Movement in Edo.

We begin by laying out the basic facts about verb movement in Edo, motivating a Pollock 1989-style account.

Edo is a (nearly) uniformly head-initial language. The basic word order is Subject-Auxiliary-Verb-Object; PPs and other complements or adjuncts follow the object:

- (1) Òzó ghá hàè íghó nè Úyì.
 Ozo FUT pay money to Uyi.
 ‘Ozo will pay money to Uyi.’

As in English, adverbs in Edo can occur in at least two places: they can be VP-final, or they can appear before the verb, following the auxiliary if there is one. Unlike English, however, the same adverbial forms cannot appear in both places. Some adverbs, such as *giegie* ‘quickly’ and *gele* ‘truly’ appear only between the auxiliary and the verb; others, like *egiegie* ‘quickly’ and *zurozuro* ‘foolishly’ appear only finally, as shown in (2).

- (2) a. Òzó ghá gié!gié/gé!lé/*ègié!gié/*zùròzùrò kó!kó ògó.
 Ozo FUT quickly/truly/*quickly/*foolishly gather bottle
 ‘Ozo will quickly/truly gather the bottles.’
- b. Òzó ghá kòkó ògó ègiégié/zùròzùrò/*gié!gié/*gé!lé.
 Ozo FUT gather bottle quickly/foolishly/quickly/truly
 ‘Ozo will gather the bottles quickly/foolishly.’

Tense and related notions in Edo can be expressed in one of three ways: by tone, by an auxiliary, or by an affix.¹ The simple past/nonpast contrast is marked only by tones on the verb. Simplifying somewhat, past tense verbs have high tone on their last syllable, while present tense verbs have a low tone in this position. Most other types of tense/aspect/mood are expressed by an auxiliary before the verb. Some common elements of this kind are listed in (3).

- (3) ghá future
 ghá present progressive/imperfective
 ghá!á past habitual/imperfective
 í nonpast negative
 má past negative

These elements are in complementary distribution with each other, suggesting that they compete for insertion into the same phrase structure position or set of positions. For simplicity of exposition, we assume that they realize a single functional head, and refer to that head as Infl—although more intricate analyses are certainly possible.

Finally, there is one ordinary suffix in the Edo tense system, which we refer to as the RV suffix. Phonologically, the vowel of this suffix harmonizes with the final vowel of the verb root, and the [r] is deleted under certain prosodic conditions not shown here (see Agheyisi 1990 for details). Semantically, the RV suffix seems to express something like past perfective. In simple sentences, it contrasts with the simple past to express a subtly different meaning, as in (4).

- (4) a. Òzó vbié là ífuánròìgbé.
 Ozo sleep(PAST) for minute ten.
 ‘Ozo slept for ten minutes.’

¹There is also a VP-final particle *ne*, which expresses the perfect. It can cooccur with the Infl particles in (3), so presumably it realizes some other, head-final functional category. It is not discussed further here.

- b. Òzó vbié-rè là ífuánrò ìgbé.
 Ozo sleep-RV for minute ten.
 ‘Ozo has slept for ten minutes.’ (completive, suggests he woke up refreshed)

On stative verbs, the RV suffix usually gives a past inchoative meaning; for example, *sún* is a stative verb meaning ‘be smooth’, and *súnrùn* means ‘became smooth.’ Crucially, the RV suffix cannot cooccur with any of the auxiliary elements listed in (3):

- (5) a. *Úyì ghá vbié-rè.
 Uyi FUT sleep-RV
 ‘Uyi will have slept.’
- b. *Òzó ghá!á kpó!ló-rò.
 Ozo PST/HAB sweep-RV
 ‘Ozo used to have swept.’
- c. *Àdésúwà òré Òzó má kó!kó-rò.
 Adesuwa FOC Ozo not raise-RV
 ‘It’s Adesuwa that Ozo has not raised.’

This is easily explained if the features of past perfective that are associated with RV are also generated in Infl. They are thus in competition with the features that are realized as the various auxiliaries, so that only one can appear at a time. If that is so, then the verb must raise to Infl at some level to combine with (or to check) the RV suffix, given standard assumptions.

The obvious next question is whether this Verb-raising is overt, prior to Spell-out, or covert, after Spell-out. The VP-initial adverbs in (2a) provide crucial evidence on this point. It turns out that Edo verbs come before this type of adverb if and only if the verb bears the RV suffix, as shown in (6) and (7).

- (6) Òzó rré-*(rè) gié!gié.
 Ozo come-RV quickly
 ‘Ozo has quickly come.’
- (7) Òzó gié!gié rré(*-rè).
 Ozo quickly come(*-RV)
 ‘Ozo quickly came.’

Thus, we conclude that V-to-Infl raising happens overtly in the Edo past perfective.²

²Note that (unlike parallel examples in French), we know that (6) involves verb movement over a VP-initial adverb and not simply a VP final adverb because of the form of the adverb, which is *gié!gié*, not *egiegie*.

Some elements that look like VP-initial adverbs block verb raising, and therefore cannot cooccur with the RV inflection at all. An example is *feko* ‘slowly’: one can have *Ozo feko saan*. (Ozo slowly jumped), but not **Ozo saan-ren feko* (Ozo jumped-RV slowly) with any word order. We conjecture that these elements are not really adverbs adjoined to VP, but rather are heads that select VP complements in their own right. Under this assumption, verb movement over these elements violates the Head Movement Constraint. However, we do not have conclusive independent evidence for this view.

2. Verb Raising and Direct Objects.

So far the analysis is quite parallel to the standard account of word order in French, except that only one tense triggers verb raising in Edo. However, Verb raising in Edo is also subject to a salient restriction that does not hold in French and other canonical verb-raising languages. In particular, V-to-I raising is blocked in Edo when the verb is transitive, as shown in (8).

- (8) *Òzó lé-rè gié!gié ìyán nà.
 Ozo cook-RV quickly yam this
 ‘Ozo has quickly cooked this yam.’

The problem here is not simply the absence of linear adjacency between the verb and the object, because the example is still bad when the intervening adverb is omitted, as in (9):

- (9) *Òzó lé-rè ìyán nà.
 Ozo cook-RV yam this
 ‘Ozo has cooked this yam.’

However, verb raising does become possible when the object is extracted by clefting or some other *wh*-movement process, as shown in (10):

- (10) Ìyán nà; òré Òzó lé-rè gié!gié t_i
 yam this FOC Ozo cook-RV quickly
 ‘It is this yam that Ozo has quickly cooked.’

Verb raising is also possible with unaccusative-type verbs, which have an NP complement underlying but one that moves to the subject position to get Case. Thus, one finds contrasts like the one in (11).

- (11) a. Òzó guòghó(*-rè) àkhé.
 Ozo break-RV vase.
 ‘Ozo has broken the vase.’
 b. Àkhé_i guòghó-rè (gié!gié) t_i
 pot break-RV quickly.
 ‘The pot has (quickly) broken.’

However, transitive verbs with their objects in place simply cannot occur in this particular tense.

Why does the presence of an overt object impede V-raising and the use of the -RV suffix? Agheyisi 1990 and Omoruyi 1991 claim that this effect is phonological in nature: the RV suffix is deleted by certain elision rules that regularly apply between vowel-final verbs and their vowel-initial objects. However, not all aspects of this putative deletion process are independently motivated phonologically. Moreover, this approach does not account for the ungrammaticality of (8), where the verb is not string-adjacent to a vowel-initial complement. Therefore, we need a more syntactic explanation.

The contrasts in (8) to (11) suggest that this effect has more to do with Case-licensing than with theta-role assignment, since trace objects are compatible with verb-raising, even though overt objects are not. This is confirmed by the fact that other kinds of material inside VP also do not block verb raising, such as CPs and PPs.

- (12) a. Òzó mián!mián-rén gèlé wèé Úyì dé ìyán
 Ozo forget-RV truly that Uyi buy yam
 'Ozo has truly forgotten that Uyi bought yams.'
- b. Àmè òré Òzó tùé-rè (gié!gié) yè íkóróbá.
 water FOC Ozo pour-RV quickly into bucket
 'It's water that Ozo has quickly poured into the bucket.'

However, it is one thing to diagnose an effect and another thing to explain it. Why should Case checking of the object be disrupted when (and only when) verb raising occurs? Similar phenomena are attested in other languages: for example, there are comparable transitivity restrictions on Quotative Inversion in English and Stylistic Inversion in French (Collins and Branigan 1997), and on verb raising to Infl in Bambara (Koopman 1992), to mention a few important cases. However, the theoretical accounts that have been offered for these paradigms do not generalize well to Edo. For example, Collins and Branigan's account of the English and French cases crucially hinges on the fact that the subject does not raise out of VP to Spec of IP in the inversion constructions; because of this, Case-checking of the object and the subject interfere with each other at LF. However, this idea cannot apply to Edo, because the subject clearly does raise to Spec, IP overtly in sentences like (8). Koopman 1992, on the other hand, argues that there is an explicit parameter of UG that concerns whether Case-chains can be formed or not: in French, the verb in Infl can form a chain with its trace to assign Case to the object, whereas in Bambara this is impossible. However, in addition to not fitting very well with current thinking about what can be a parameter,³ Edo does not show the cluster of properties that it should if it had the Bambara setting of Koopman's parameter.⁴ Therefore, while we agree with these authors that verb raising somehow comes into conflict with the Case licensing of objects in some languages and some constructions, we need to say something new about why this is so.

It is reasonable to say that a verb must be in a local configuration with the NP whose Case it checks at the point where checking occurs. This intuition can be formulated as in (13).

- (13) Case checking happens only if the checker and the checkee are in the same minimal domain at the relevant point (LF for weak features; before Spell-Out for strong features).

³It does not reduce to lexical properties of functional heads (Borer 1984; Chomsky 1995), and it does not directly concern visibility conditions (Baker 1988, 1996).

⁴In particular, there is no P insertion with predicate nominals in Edo, and *wh*-movement is possible (indeed, required). Like Bambara, there is no equivalent of *there*-insertion constructions in Edo, but that is not too surprising, since this class of expletive construction is somewhat rare crosslinguistically.

On the standard account of French, the tensed verb moves away from the NP that is dependent on it for Case, in a way that threatens to violate (13). However, it is also standard to assume that NPs in French ultimately move to have their Case checked; this movement can restore the locality between the verb and the object at LF, as in (14).

(14) Spell-Out

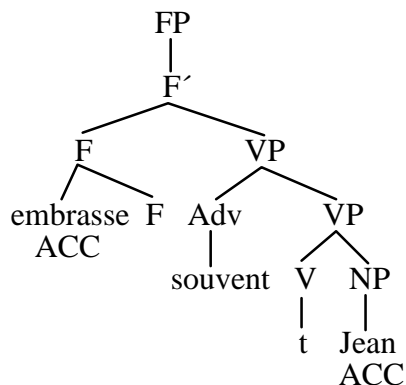

LF

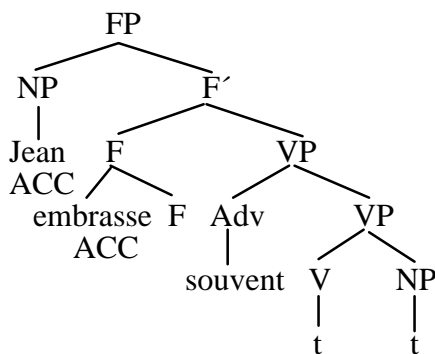

Suppose, however, that the checking position for objects in Edo is lower, perhaps even within the basic VP. Then if the verb raises to combine with an RV suffix in Infl, there will be no procedure for restoring a local configuration between the verb and the object, and the sentence will be ungrammatical. Thus, the LF for (8) in Edo is essentially the same as the Spell-Out representation in French; it violates (13).

Is there independent evidence for the crucial assumption that the Case-checking position of the object is different in French and Edo? Perhaps yes. Consideration of ordinary NPs is of little help, since they appear in more or less the same position at Spell-out in both languages, and LF movement of these NPs is difficult to detect. However, there is one special type of object that could be more revealing: namely weak pronominal clitics. In many languages, these do not appear in the same place as full noun phrases. For example, in French they are obligatorily left-adjoined to the highest tensed verb, often an auxiliary:.

(15) Jean *l'*a vu. (Compare: Jean a vu *la maison*.)
 Jean *it*-has seen John has seen the house

Suppose that we say, following Noonan (1992) and others, that this happens because the movement that happens only at LF for normal NPs happens overtly for certain pronouns.

Now compare French with Edo in this respect. Edo also has weak object pronouns that behave as clitics by standard morphosyntactic tests (see Pulleybank 1986 for related Yoruba). However, these weak pronouns are never attracted to the tense/auxiliary position. Indeed, they do not move at all. Thus, (16) contrasts with (15).

(16) Òzó ghá lè é̀rè. (*Òzó é̀rè ghá lè.)
 Ozo FUT cook it Ozo it FUT cook

This gives some independent support for the claim that objects do not raise in order to get Case in Edo. As a result, verbs can raise to Infl in this language--but only if they do not have an object to Case-license, because they will never be reunited with that object in the normal course of affairs (unless *wh*-movement occurs; see note .5).

This proposal makes the following crosslinguistic prediction. Languages with object-clitic climbing into the Infl space must have objective Case checked in a high position; therefore if they also have verb raising into the Infl space, it should not show transitivity restrictions. Contrapositively, languages with transitivity restrictions on verb raising should never have high placement of object clitics. (Note that the converse does not necessarily hold true, because there might be other restrictions on clitic climbing that we do not know about, causing it to be delayed until LF.) (17) lists some Indo-European languages and West African languages relevant to evaluating this prediction. Particularly striking is the contrast between English and other Germanic languages: On the standard analysis, English has no verb raising of transitive verbs out of the VP and no object movement, even for pronouns; other Germanic languages have both.

(17)	<u>verb raising is unrestricted</u>	<u>high object clitics</u>
French, Italian, ...	YES	YES
Welsh	YES (VSO order)	YES (if C particle present)
German/Dutch	YES (e.g. in V2)	YES
Scandinavian	YES (e.g. in V2)	YES (Object shift)
English	NO (in quotative inversion)	NO
Edo	NO	NO
Bambara	NO (Koopman 1992)	NO (in same places as NPs)
Yoruba	NO (or not applicable)	NO
Gbadi	YES (Koopman 1984)	YES (Koopman. 1984)
Vata	YES (Koopman 1984)	MAYBE
Igbo	YES	YES

Another instructive near-minimal comparison is Edo with the nearby language Igbo. Déchaine (1993:ch. 8) argues at length that verbs raise at least as far as aspect or affirmation/negation in Igbo. As a result, negation and progressive show up as verbal suffixes in Igbo, whereas they are preverbal particles in Edo. This is illustrated in (18).

- (18) a. Ékhè é-rí-**hun** rin à. IGBO (cf. EDO: Òzó **má** rrí èvbàré nà.)
 Ekhe AGR-eat-**NEG** food this. Ozo **not** eat food this
 Ekhe didn't eat this food.
- b. Ékhè rí-**ga** rin à. IGBO (cf. EDO: Òzó **ghá** rri èvbàré nà.)
 Ekhe eat-**PROG** food this. Ozo **PROG** eat food this
 Ekhe is eating this food.

Moreover, there is no transitivity restriction on verb raising in Igbo: the suffix forms show up just as well with transitive verbs as with intransitives. There is also a subtle but important difference between Igbo and Edo in the position of object clitics. Goal NPs usually come before theme NPs in the double object constructions of both languages, as

shown in (19a). However when the theme is a weak pronoun, it is attracted to the verb so that it appears before the goal object in Igbo but not in Edo (see (19b)).

- (19) a. Òbí nyè-re Chíké egó/??ya. IGBO (EDO: Òzó hàè Úyì íghó / rè)
 Obi give-RV Chike money/??it Ozo paid Uyi money /it
 ‘Obi gave Chike some money/it.’
- b. Òbí nyè-re ya Chíké. IGBO (EDO: *Òzó hàè é̀rè Úyì)
 Obi give-RV it Chike Ozo paid it Uyi
 ‘Obi gave Chike it.’

This fact leads Saah and Eze (1997) to analyze Igbo clitics as placed in a high head position (AgrO, they claim), parallel to a common analysis of clitics in French. Thus, Igbo and Edo differ both in the existence of unrestricted verb raising and in the placement of object clitics, in a way that supports our analysis.

This obviously only counts as a preliminary result. More languages need to be checked to fully evaluate this prediction, and no doubt one will ultimately have to combine the proposal with a finer analysis of the Infl space that pays attention to the possibility of V-movement and object cliticization targeting different heads in this space. However, we can already see that the initial prediction is borne out over an interesting range of languages.⁵

3. Verb Movement and Serialization.

Next we turn to a second gap in the distribution of verb raising in Edo that also proves theoretically instructive; it concerns Serial Verb Constructions (SVCs). SVCs are constructions in which more than one verb appears in sequence with a single overt subject and no markers of coordination or subordination. (20) gives paradigmatic examples of two somewhat different kinds of SVCs in Edo (Stewart 1998).

- (20) a. Òzó lé èvbàré ré. CONSEQUENTIAL SVC (CSVC)
 Ozo cook food eat
 Ozo cooked food and ate it.
- b. Òzó (gié!gié) suá àkhé dé RESULTATIVE SVC (RSVC)
 Ozo (quickly) push pot fall.
 ‘Ozo quickly pushed the pot down.’

Both kinds of SVC can have at most one tense/mood auxiliary, which appears before the first verb of the sequence, as shown in (21).

- (21) a. Òzó ghá lè èvbàré (*ghá) rè.

⁵We leave open the exact mechanisms of why *wh*-movement of the direct object makes verb raising possible in Edo, as shown in (10)—an effect also found in Quotative Inversion in English, and Stylistic Inversion in French. There are two obvious possibilities. First, it could be that *wh*-traces simply do not need to be Case-checked in the relevant sense, since they are phonologically empty (Borer 1984). Alternatively, it could be that *wh*-movement can leave a trace in the specifier of the head that is targeted by verb movement in Edo. In this way, it can establish a Case-checking configuration with the raised verb in a way that is not available to other objects in the language.

Ozo FUT cook food (*FUT) eat
 ‘Ozo will cook the food and (*will) eat it.’

- b. Òzó ghá suà àkhé (*ghá) dè.
 Ozo FUT push pot (*FUT) fall
 ‘Ozo will push the pot down.’

Exactly the same judgments hold with the past negation morpheme *má* replacing *ghá* in these examples. Thus, these structures clearly involve two verbs that are somehow in the domain of a single Infl node.

The interesting question for our purposes is what happens when past perfective is chosen as the Infl in an SVC structure, so that verb movement is triggered. In fact, there is no possible outcome for such a numeration in Edo. One might think that only the first verb of the SVC would be attracted, so that the RV would show up as an affix on the first verb. The other plausible possibility is that the RV affix could distribute over the two verbs, showing up as an affix on both. In fact, both possibilities are ruled out:

- (22) a. *Èvbàré òré Òzó lé-rè (gé!lé) khién(-rèn). CSVC
 food FOC Ozo cook-RV truly sell(-RV)
 ‘It’s food that Ozo has truly cooked and sold.’
- b. *Àkhé òré Òzó suá-rè (gié!gié) dé(-rè). RSVC
 pot FOC Ozo push-RV quickly fall(-RV)
 ‘It’s the pot that Ozo has pushed down.’

(Note that the object must be clefted, given the results of the last section.) Indeed, there is no way to have an SVC in past perfective in Edo; one has to be content with using the simple past. Neither can a verb in an SVC ever come before the first VP-initial adverb. Note that a rather similar phenomenon is found in the one serial verb(-like) construction found in English: one can say *John will come see me tomorrow*, but not **Yesterday John came see/saw me*. This English fact has received some discussion in the verb movement literature (Jaeggli and Hyams 1993), but no standard account has emerged.

We propose that what goes wrong with the structures in (22) is this. The Infl needs to attract a verb in order to satisfy its affixal property. More specifically, it needs to attract the closest verb, given Chomsky’s definition of Attract in (23).

- (23) K attracts F if F is the closest feature that can enter into a checking relation with a sublabel of K. (Chomsky 1995: 297)

Here A is closer to K than B if A c-commands B, plus perhaps an “equidistance” condition involving head chains that does not concern us here (Chomsky 1995: 356). Now, SVCs are special in that there is no closest verb to attract. Rather, there are two verbs, interpreted more or less in parallel, neither of which is the complement of the other. Following Baker 1989, it is plausible to say that in SVCs the two verbs are at essentially the same level of syntactic structure, as in the schematic structure in (24).

- (24) [IP NP [V__]-RV [VP ... V₁ V₂ ...]]

The idea, then, is that *Attract* fails in this situation, so that the affixal property of RV is not satisfied, leading to a crash. This result is achieved if we state *Attract* as in (25).

- (25) X attracts Y iff Y can check a feature of X, and for all Z such that Z is not equal to Y and Z can check this feature of X, Y asymmetrically c-commands Z.

This is essentially the same as Chomsky's condition, except that in cases where more than one element is at the same level of structure, Chomsky's condition can be understood as allowing either element to be attracted, whereas (25) clearly implies that neither will be attracted.⁶ (Note that (25) blocks the attraction of V to I even at LF; thus it can explain the ungrammaticality of **Yesterday John came see/saw me.* in English: the verbal features of tense remain unchecked at that level.)

SVCs contrast minimally with constructions like the one in (26) (Stewart 1998).

- (26) Òzó gé!lé mián!mián kìé èkhù. ASPECTUAL VERB CONSTRUCTION
 Ozo truly forget open door
 'Ozo truly forgot and opened the door.'

Like SVCs, the Aspectual Verb Construction consists of a sequence of bare verbs on the surface. However, in these examples the RV affix can successfully attract the first verb:

- (27) Òzó miánmián-rèn gé!lé kìé èkhù.
 Ozo forget-RV truly open door
 'Ozo has truly forgotten and opened the door.'

This goes along with the fact that (26) can be analyzed as a relatively normal complementation structure of the kind that can be found in English; the verb *mianmian* selects a VP complement or an extended projection thereof. The structure is roughly as shown in (28). When the -RV in Infl needs to attract a verb, one of the verbs in the construction is clearly closer to Infl in the sense of c-command than the other, so *Attraction* succeeds in this case.

⁶ Our proposal is not compatible with some recent analyses of inversion constructions and super-raising, which crucially make use of the idea that either of two phrases can be attracted when they are at the same level of structure. While we cannot attempt to harmonize the results here, two possibilities can be pointed out. First, it could be that in the inversion constructions in question the Infl actually has slightly different features that determine which phrase is attracted. If so, then (25) is satisfied. Alternatively, there could be a more fundamental difference between phrasal movement and head movement that affects how equidistance is dealt with; note that there seems to be no equivalent of super-raising for heads, for example).

(28)

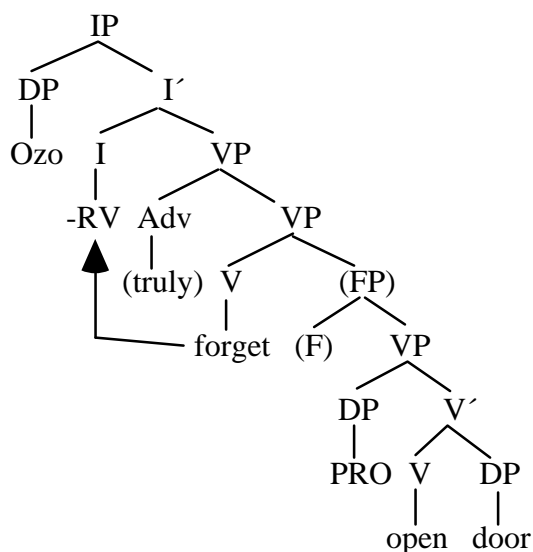

Our proposal also explains the minimal contrast between the ordinary RSVC in (29a) and a nearly synonymous construction with a resultative adjectival phrase in (29b). The transitive verb *koko* 'raise' can raise to Infl in the second example, but not the first:

- (29) a. Àdésúwà òré Òzó kó!kó(-*ró) mó!sé.
 Adesuwa FOC Ozo raise-RV be.beautiful(V)
 'It's Adesuwa that Ozo raised to be beautiful.'
- b. Àdésúwà òré Òzó kó!kó-(ró) m̀sè.
 Adesuwa FOC Ozo raise-RV beautiful(A)
 'It's Adesuwa that Ozo raised to be beautiful.'

This shows that there is no inherent problem with raising a verb out of a resultative construction. Perhaps (29a) and (29b) are even parallel structurally as well as semantically. However, in (29a) is the result-denoting head a verb. Unlike the adjective, this verb is second potential candidate for attraction to Infl. Thus, there is a unique closest verb for Infl to attract in (29b), but not in (29a), so (29a) is ruled out by (25).

The analysis given so far covers the basic facts of Edo fairly well. However, a broader crosslinguistic perspective suggests a refinement. Consider again the Igbo language. In section 2, we saw that this is a neighboring language of Edo that has verb raising, in which verbs always bear an inflectional suffix. Igbo also does not have Edo-like serial verb constructions. Rather, the equivalents of resultative SVCs in Edo show up in the form of V-V compounds; (30) is comparable to (20b), for example.

- (30) Obi kwá-dà-rà Ézè (Ihionu 1992:174)
 Obi push-fall-FACT Eze
 'Obi pushed Eze down.'

However, Consequential SVCs in Edo cannot correspond to a V-V compound in Igbo: there is no (31), comparable to (20a), for example.

- (31) *Àdá sì-rí-rí jí.
 Ada cook-eat-FACT yam
 ‘Ada cooked and ate the yams.’

The closest functional equivalent to Edo’s (20a) in Igbo is the so-called consecutive construction, but this crucially has distinct Infl-type suffixes on both verbs:

- (32) Ógù si-ri okúkò ri-e OR Àdá sì-ghè jí è-rí-ghé
 Ogu cook-RV chicken eat-OVS Ada cook-prog yam pre-eat-prog
 Ogu cooked a chicken and ate it.’ ‘Ada is cooking yams and eating them.’
 (cf. Déchaine 1993:238) (Ihionu 1992:174)

This then raises two questions: (i) what is the relationship between V-V compounds in Igbo and SVCs in Edo, and (ii) why do only a subset of SVCs correspond to compounds?

To get insight into these questions, take a closer look at the statement of Attract in (25). According to this statement, Attract fails whenever there are two equally good candidates for attraction, i.e., when there is no unique highest verb in the sense of c-command. But there are two distinguishable ways that this could come about: either the two verbs could be in a relationship of mutual c-command, or the verbs could be such that neither one c-commands the other. These two situations could yield different grammatical results. With this in mind, we revise (25) slightly, as in (33):

- (33) Suppose X needs feature Y. Let Z be the set of categories that have feature Y. Then X attracts W iff W is in Z and for all V in Z, W c-commands V.

Next, we propose the rough syntactic structures for the two types of SVCs given in (34) and (35) (these simplified somewhat for expository purposes; see Stewart 1998).

(34) CSVC:

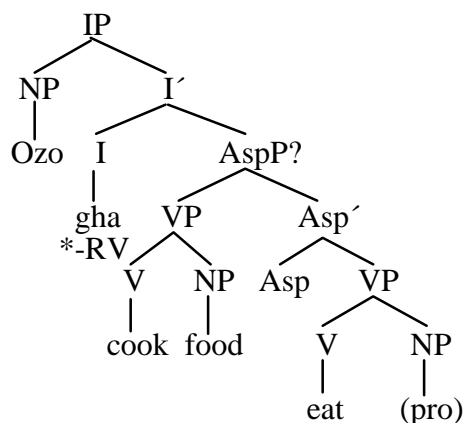

(35) RSVC:

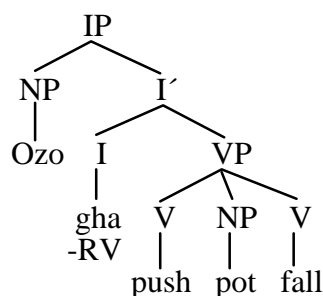

According to (33), if neither verb c-commands the other, nothing will be attracted, as before, resulting in a crash. This is the case in CSVCs that contain two transitive verbs, under the analysis in (34). When the Infl in this structure contains an attracting affix, it crashes in both Edo and Igbo. In contrast, the two verbs are in a mutual c-command

relation in the RSVC structure shown in (35). Stewart 1998 gives extensive evidence that the two types of SVCs have syntactic structures that differ in approximately this way. One particularly telling argument is that aspectual particles like iterative *ghá* can come between the two verbs in a CSVC, but not in an RSVC:

- (36) a. Òzó dùnmwún èmà ghá khién. CSVC
Ozo pound yam ITER sell
'Ozo produced pounded yam and sold it repeatedly.'
- b. *Òzó sùá ògó ghá dé. RSVC
Ozo push bottle ITER fall
'Ozo pushed the bottle(s) down repeatedly.'

This supports the claim that there is extra functional structure between the verbs in CSVCs but not in RSVCs, structure that prevents the verbs from c-commanding each other. Now in a structure like (35), an affixal Infl cannot attract one verb (as before), but it can attract both verbs, because they c-command each other. The resulting movement then creates V-V compounds like (30) in Igbo. On this perspective, what is wrong with the Edo example in (22b) is that only one of the closest Vs was attracted, whereas in fact both verbs must be. Thus, the only output from this underlying structure that is compatible with our version of Attract would be something like **Ozo sua-de-re akhe* 'Ozo push-fall-RV pot.' The equivalent of this is good Igbo (see (30)), but it is out in Edo. We attribute this to a superficial filter in the morphological component that rules out V-V compounds on the surface in Edo.

This analysis has two further implications, one typological and one theoretical. Typologically, it predicts that resultative V-V compounds will be found only in languages with verb-to-Infl movement, while SVCs will only be found in languages without V movement. This seems true. For example, Yoruba (Déchaine 1993) and Vietnamese (Duffield, personal communication) are other languages with no V movement out of VP, and they have SVCs like Edo. On the other hand, Chinese has some verb movement according to Huang 1988 (although perhaps only to a low position, such as Aspect), and it has V-V compounds rather like Igbo. Also relevant is Schiller's (1990) observation that there are no SVCs in VSO languages; this follows from our theory if VSO order necessarily involves V-raising to a functional head.

A second favorable consequence of this analysis is that it solves a problem concerning the morphological structures formed by head movement, raised by Durie 1997:304-307. The usual syntactic approach to V-V compounds in Igbo and similar languages is to say that the projection of the second verb is generated as some kind of complement to the first verb. It then incorporates into the first verb by a normal process of head movement (see, e.g., Ihionu 1992, Dikken 1995: 162-64, Collins 1997; Déchaine 1993 is similar but with somewhat different assumptions about headedness). If V-to-Infl raising is part of the language, then that is a subsequent step, independent of the movement that forms the V-V compound. This underlying structure and derivational history is illustrated in (37a), in contrast to our proposal in (37b).

- (37) a. "Standard" view
b. Our view

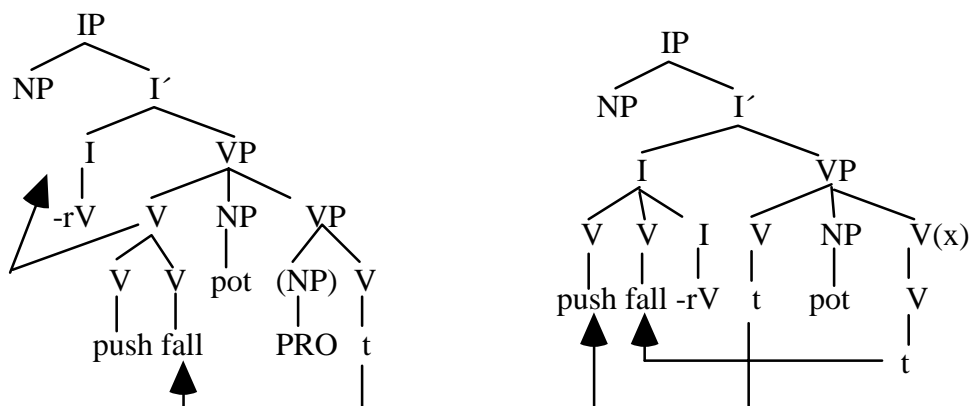

The puzzle concerning (37a) is that—in the absence of morphological subcategorization frames specifying the contrary—one would expect the second verb to adjoin to the left of the first verb, not to the right. Leftward adjunction seems to be the norm in most contexts. Within the domain of head movement in particular, Baker (1996) shows that left-adjunction is the nearly exceptionless rule whenever roots are combined by noun incorporation, or from normal verbal complementation structures. However, on the standard analysis, the resultative V-V compounds do not fit into this picture. Rather, one must stipulate that the result verb right-adjoints to the head verb in Igbo. Moreover, this same surprising order is found in Chinese, Kalam, and other languages that have resultative V-V compounding.

Our alternative proposal makes an important contribution to explaining why this should be. There is no complement relation between V1 and V2, so no question of one verb adjoining directly to the other. Instead, both are simultaneously attracted to Infl. Standard principles of head movement then state that both should be adjoined to the left of Infl in the unmarked case. However, the linear relationship between the two Vs is not determined by these principles; it is left open. As a result, the order can be determined by other factors—such as the very general iconicity principle that states that in the absence of a structural asymmetry the verb that refers to the event that happens first chronologically appears first linguistically. This is a very general effect that is seen not only in SVCs and V-V compounds (see Durie 1997:330-340 and references cited there), but also in conjunctions, clause sequencing constructions, sequences of sentences in narrative discourse, and many other constructions.

References

- Agheyisi, Rebecca. 1990. *A grammar of Edo*. ms., UNESCO.
- Baker, Mark. 1988. *Incorporation: a theory of grammatical function changing*. Chicago: University of Chicago Press.
- Baker, Mark. 1989. Object sharing and projection in serial verb constructions. *Linguistic Inquiry* 20:513-553.
- Baker, Mark. 1996. *The polysynthesis parameter*. New York: Oxford University Press.
- Borer, Hagit. 1984. *Parametric syntax: case studies in Semitic and Romance languages*. Dordrecht: Foris.

- Chomsky, Noam. 1995. *The Minimalist Program*. Cambridge, Mass.: MIT Press.
- Collins, Chris. 1997. Argument sharing in serial verb constructions. *Linguistic Inquiry* 28:461-497.
- Collins, Chris and Phil Branigan. 1997. Quotative Inversion. *Natural Language and Linguistic Theory* 15:1-41.
- Déchaine, Rose-Marie. 1993. *Predicates across categories*. Ph.D. dissertation, University of Massachusetts, Amherst.
- Dikken, Marcel den. 1995. *Particles: on the syntax of verb-particle, triadic, and causative constructions*. New York: Oxford.
- Durie, Mark. 1997. Grammatical structures in verb serialization. In *Complex Predicates*, ed. Alex Alsina, Joan Bresnan, and Peter Sells, 289-354. Stanford, Calif.: CSLI.
- Huang, C.-T. James. 1988. Wo pao de kuai and Chinese phrase structure. *Language* 64:274-311.
- Ihionu, Peter. 1992. Verb compounding in Igbo: an overview. In *MIT Working Papers in Linguistics 17*, ed. Chris Collins and Victor Manfredi, 165-182. Cambridge, Mass.: MIT.
- Jaeggli, Osvaldo and Nina Hyams. 1993. On the independence and interdependence of syntactic and morphological properties: English aspectual *come* and *go*. *Natural Language and Linguistic Theory* 11:313-346.
- Koopman, Hilda. 1984. *The syntax of verbs*. Dordrecht: Foris.
- Koopman, Hilda. 1992. On the absence of Case chains in Bambara. *Natural Language and Linguistic Theory* 10:555-594.
- Noonan, Maire. 1992. *Case and syntactic geometry*. Ph.D. dissertation, McGill University.
- Omoruyi, T. 1991. Tense, aspect, and modality in Edo. *Afrika und Ubersee* 74:1-19.
- Pollock, Jean-Yves. 1989. Verb movement, Universal Grammar, and the structure of IP. *Linguistic Inquiry* 20:365-424.
- Pulleybank, Douglas. 1986. Clitics in Yoruba. In *Syntax and Semantics 9: the Syntax of Pronominal Clitics*, ed. Hagit Borer, 43-64. New York: Academic Press.
- Saah, Kofi and Ejike Eze. 1997. Double objects in Akan and Igbo. In *Objects in Benue-Kwa*, ed. Rose-Marie Dechaine and Victor Manfredi, 139-151. The Hague: Graphics Academic Press.
- Schiller, Eric. 1990. The typology of serial verb constructions. In *Papers from the 26th regional meeting of the Chicago Linguistics Society*, ed. Michael Ziolkowski, Manuela Noske, and Karen Deaton, 393-406. Chicago: Chicago Linguistics Society.
- Stewart, O.T. 1998. *The serial verb construction parameter*. Ph.D. dissertation, McGill University.

Department of Linguistics
Rutgers University
18 Seminary Place
New Brunswick, NJ 08903

mabaker@rucss.rutgers.edu